

# ELEMENTS OF MECHANICAL ENGINEERING

## PART – A

### UNIT – IV

## *Refrigeration and Air-Conditioning*

Unit - III

## Objectives:

1.1 Refrigerants & Properties.

1.2 Definitions, Refrigerating effect, tonnage, Ice making capacity.

1.3 COP

1.4 Principle & working of vapor compression and absorption.

1.5 Principles & application of air conditioners & room air conditioner.

Refrigeration is defined as “the transfer of heat from a lower temperature region to a higher temperature one.”<sup>1</sup> Refrigeration devices that produce refrigeration operate using the vapor-compression cycle (reversed Carnot cycle). Some examples of refrigeration devices are heat pumps, refrigerators, automotive air-conditioners, and residential/commercial air-conditioners. All of these devices have one thing in common, to reduce the temperature of an enclosed environment.

Unit – IV,

*Refrigeration and Air-Conditioning*

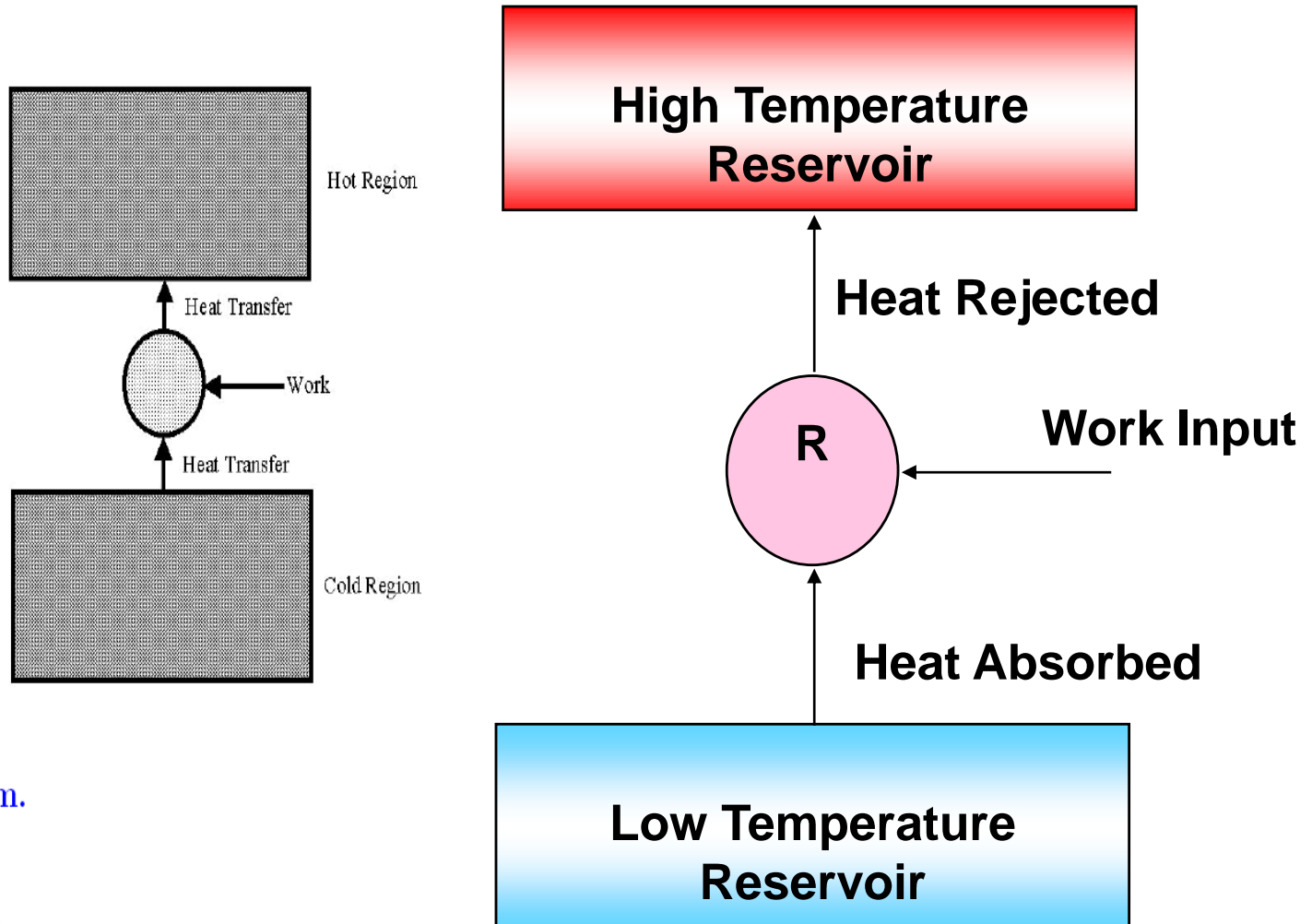

A refrigeration system.

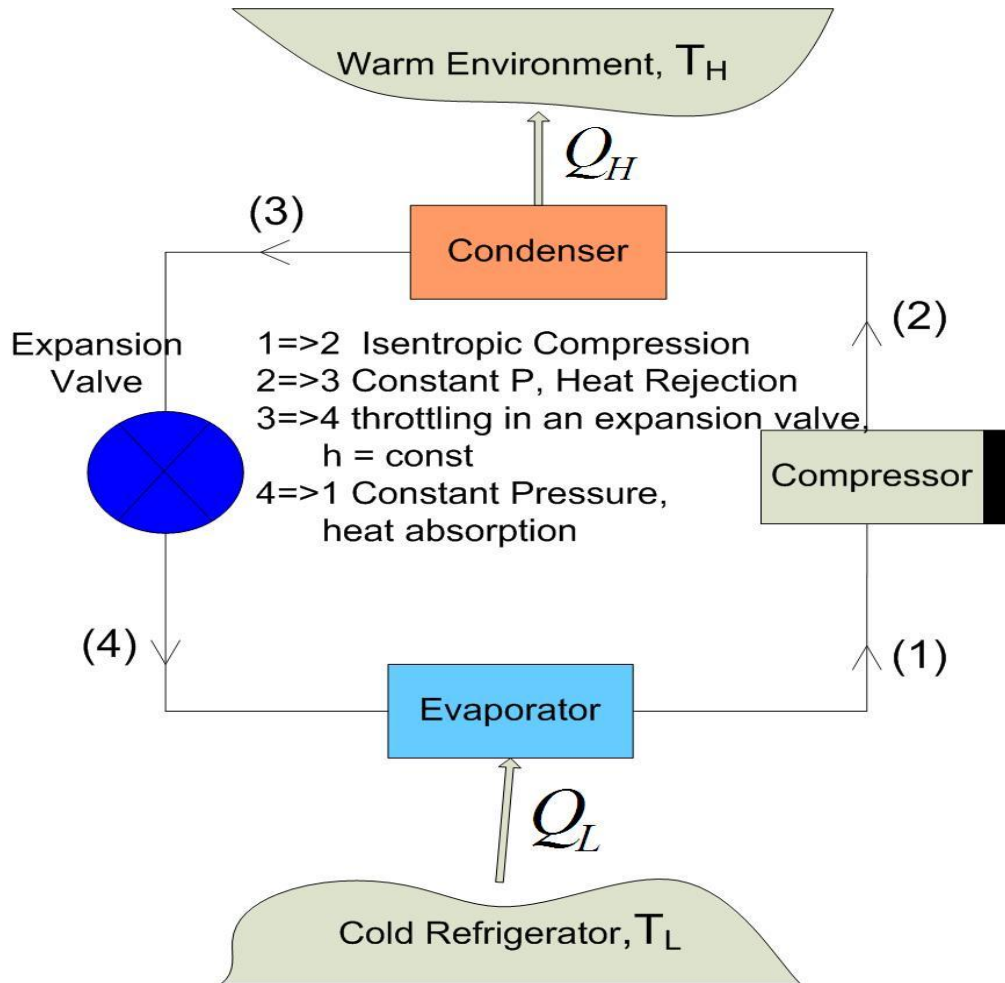

It is the process of continuous cooling/ extraction of heat with in a space with the help of external work.

Principle of Refrigeration: - Second law of Thermodynamics – heat flow from cold to hot body – external source – reversed heat engine.

Refrigerator – m/c – produce cold – remove heat(Space) – reject(atmp) – temp below surrounding temp.

Refrigerant : Working fluid – gas/ liquid- Ammonia, Methyl chloride, Freon -12, 13,22, carbon dioxide, Sulphur dioxide, brine, Air, Water etc..

A refrigerator is a machine that removes heat from a low temperature region. Since energy cannot be destroyed, the heat taken in at a low temperature must be dissipated to the surroundings. The Second Law of Thermodynamics states that heat will not pass from a cold region to a warm one without the aid of an “external agent”. Therefore, a refrigerator will require this “external agent”, or energy input, for its operation.

Refrigerating effect  $Q$  – amt of heat energy removed/unit time  
– fm space –

Capacity of refrigerator – kW or kJ/s, kJ/min.

Ton of Refrigeration : Std Unit – freezing capacity of water – a ton of refrigeration is defined as the amount of heat to be extracted from one ton of water at  $0^{\circ}\text{C}$  and to freeze it to ice at  $0^{\circ}\text{C}$ . = mass of ice x latent heat / time

In SI units = 210 kJ/min = 3.5 kW

Ice making capacity : ability to make ice – starting from water at room temp.

$\text{COP} = \text{Refrigerating effect} / \text{work i/p} = \text{o/p} / \text{i/p} = Q/W$

Relative COP = Actual COP / Theoretical COP ( laws of thermodynamics)

### Types of Refrigerants:

- 1) Primary : take part directly in process.
- 2) Secondary : first cooled with the help of Primary – further used for cooling – water, brine.

### Types of Refrigeration system

- 1) Based on type of external work ---
  - Using Mechanical energy – a) Cold air refrigeration  
b) Vapour compression refrigeration
  - Using heat energy : a) Simple vapour absorption refrigeration  
b) Actual vapour absorption refrigeration.
- 2) On usage : Primary & Secondary refrigeration.

## Coefficient of Performance

The purpose of the refrigerator is to remove heat from the cold region while requiring as little external work as possible. A measure of the efficiency of the device is therefore:

Coefficient of Performance (COP) =

$$\frac{\text{Rate of heat removal from the cold region}}{\text{Rate work is done}} = \frac{\dot{Q}}{\dot{W}}$$

**Definitions:**

**Coefficient of Performance (COP)** – the ratio of desired output divided by the required input. It is the rate of how well the heat pump or refrigerator is performing.

**Compressor** – pump used to push refrigerant through the system.

**Condenser** – heat exchanger used to reject heat energy.

**Cooling capacity** – the rate of heat removal from the refrigerated space, which is expressed in terms of tons of refrigeration.

**Evaporator** – heat exchanger used to absorb heat energy.

**Expansion valve** – controls the flow of refrigerant and allows for phase change from a liquid to vapor.

**Flash chamber** – mixing chamber where both liquid and vapor are stored.

**Refrigerant** – the working fluids used in the refrigeration cycles.

**Refrigeration** – the heat transfer of heat from a lower temperature region to a higher temperature one. A device called a refrigerator or heat pump accomplishes refrigeration.

**Refrigerator** – the device used to produce refrigeration.

**Thermocouple** – Temperature sensor consisting of the junction of two dissimilar metals. The output voltage produced is a function of the difference in the temperature between the hot and cold junction.

**T-s diagram** – schematic or graphical representation of the temperature versus entropy for refrigeration cycles.

## **Refrigeration systems for industrial processes**

- **Small capacity modular units of direct expansion type (50 Tons of Refrigeration)**
- **Centralized chilled water plants with chilled water as a secondary coolant (50 – 250 TR)**
- **Brine plants with brines as lower temperature, secondary coolant (>250 TR)**

## Refrigeration at large companies

- **Bank of units off-site with common**
  - Chilled water pumps
  - Condenser water pumps
  - Cooling towers
- **More levels of refrigeration/AC, e.g.**
  - Comfort air conditioning (20-25 °C)
  - Chilled water system (8 – 10 °C)
  - Brine system (< 0 °C)

# Parts & Functions

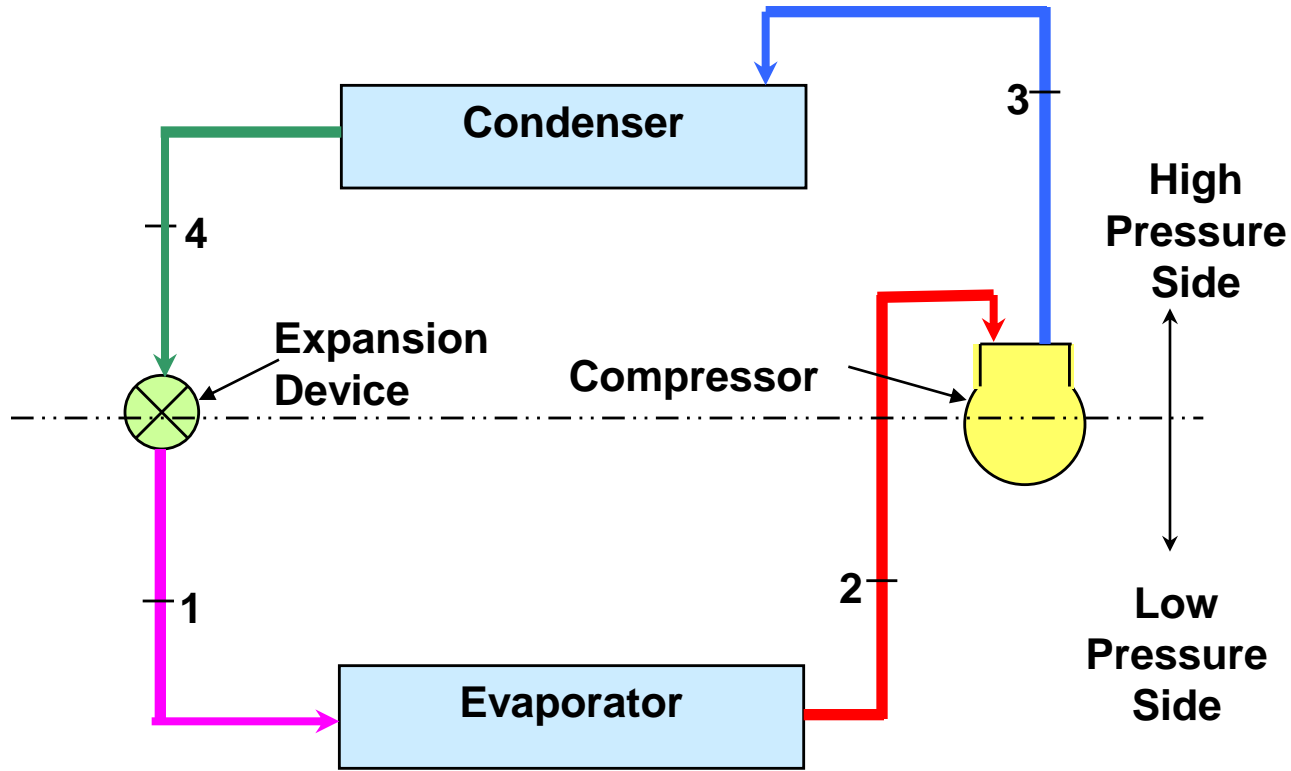

## Parts & Functions

1) **Compressor:** Compressor is the heart of the refrigeration system. The power required for transmitting heat from low temperature space to high temperature space is given here. When Freon gas passes through a compressor it gets highly compressed i.e. pressurized and its temperature also becomes very high. As it leaves the compressor, Freon gets converted into the gaseous state.

2) **Condenser:** All the heat the Freon has absorbed from the substance at low temperature is thrown out to the atmosphere via the condenser. For household refrigerators, the condenser is usually a coil of copper exposed to the atmosphere. When Freon passes through this coil it gives up its heat partially to the atmospheric or surrounding air and its temperature reduces, but its pressure remains unchanged. In case of the bigger refrigerators water cooled condensers are used.

## Parts & Functions

3) **Expansion valve:** When the high pressure and low temperature Freon passes through expansion valve its pressure reduces suddenly and along with it its temperature also reduces suddenly and drastically. In the household refrigerator usually capillary, a thin copper tube is used as the expansion valve. Freon leaving the expansion valve is partially in liquid state and partially in gaseous state.

4) **Evaporator:** The freezer section of the refrigerator is the evaporator which is in the form of various coils of copper or aluminum tubing. Here the foods or the substances which are initially at higher temperature are kept for cooling. When the low temperature and low pressure Freon passes through the evaporator, it chills the freezer space and food items kept here. It absorbs the heat from the substances to be chilled and so its temperature raises as does its pressure. It leaves the evaporator or freezer in the vapor state and then enters into the compressor where the cycle is repeated.

## Parts & Functions

**4) Absorber:** it is a unit contains water. Receives refrigerant from evaporator – form strong soln with increase in temp.

**5) Generator (Separator) :** used to separate refrigerant vapour from strong soln using heat energy and then send it to condenser.

**Properties of Ideal refrigerant:** Low viscosity, Low boiling point, low specific volume, high COP, High heat of vaporization, Non toxic, non corrosive, odourless, low freezing pt, low specific heat capacity, low saturation pressure, good thermal conductivity, non inflammable, non explosive, enable to detect in case of leakage, economical initial & maintenance cost.

**Uses of refrigerants:**

Ammonia: Ice plants, large cold storages.

Fluorocarbon refrigerants: Freon 11, 12, 13, 22, 113, 114 - -

Domestic refrigerators, water coolers, A/c Plants, cold storage.

Sulphur dioxide: Domestic refrigerator.

## USES of Refrigeration:

Ice, preservation of Food/medicines, A/c, Transportation of food stuffs, dairy products, flowers, industrial processes etc.

## Refrigeration systems

- **Vapour Compression Refrigeration (VCR):**  
uses mechanical energy : refrigerant vapour is compressed in compressor, condensed in condenser, expanded in expansion valve and Evaporated in the evaporator.
- **Vapour Absorption Refrigeration (VAR):**  
uses thermal energy : combination of absorber & refrigerant is used. The absorber absorbs the refrigerant in solution and gives up the vapour refrigerant when heated.

# Vapour Compression Refrigeration

## Two advantages

- Lot of heat can be removed (lot of thermal energy to change liquid to vapour)
- Heat transfer rate remains high (temperature of working fluid much lower than what is being cooled)

Unit – IV,

The high pressure superheated gas is cooled in several stages in the condenser

Liquid passes through expansion device, which reduces its pressure and controls the flow into the evaporator

The superheated vapour enters the compressor where its pressure is raised

Low pressure liquid refrigerant in evaporator absorbs heat and changes to a gas

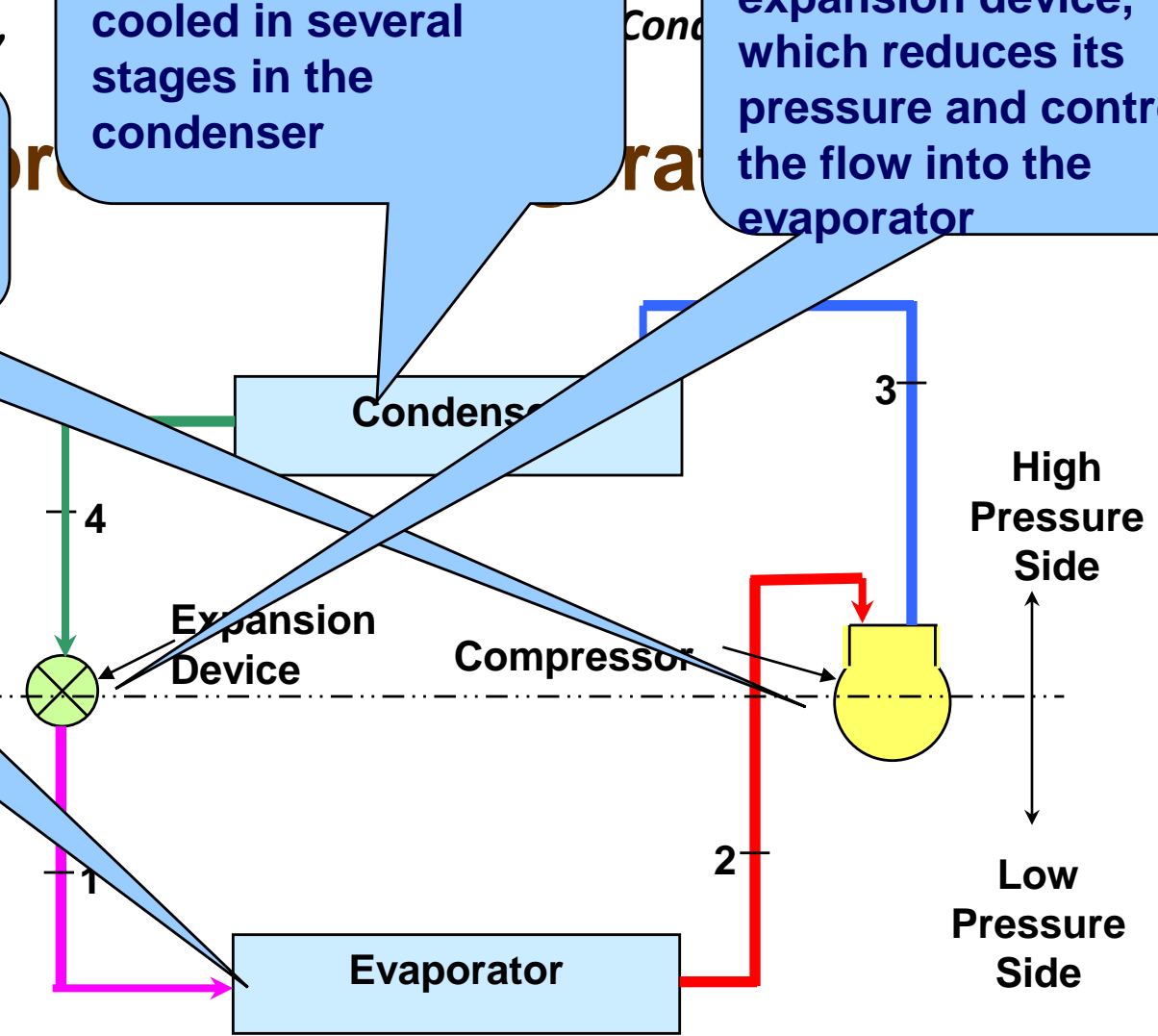

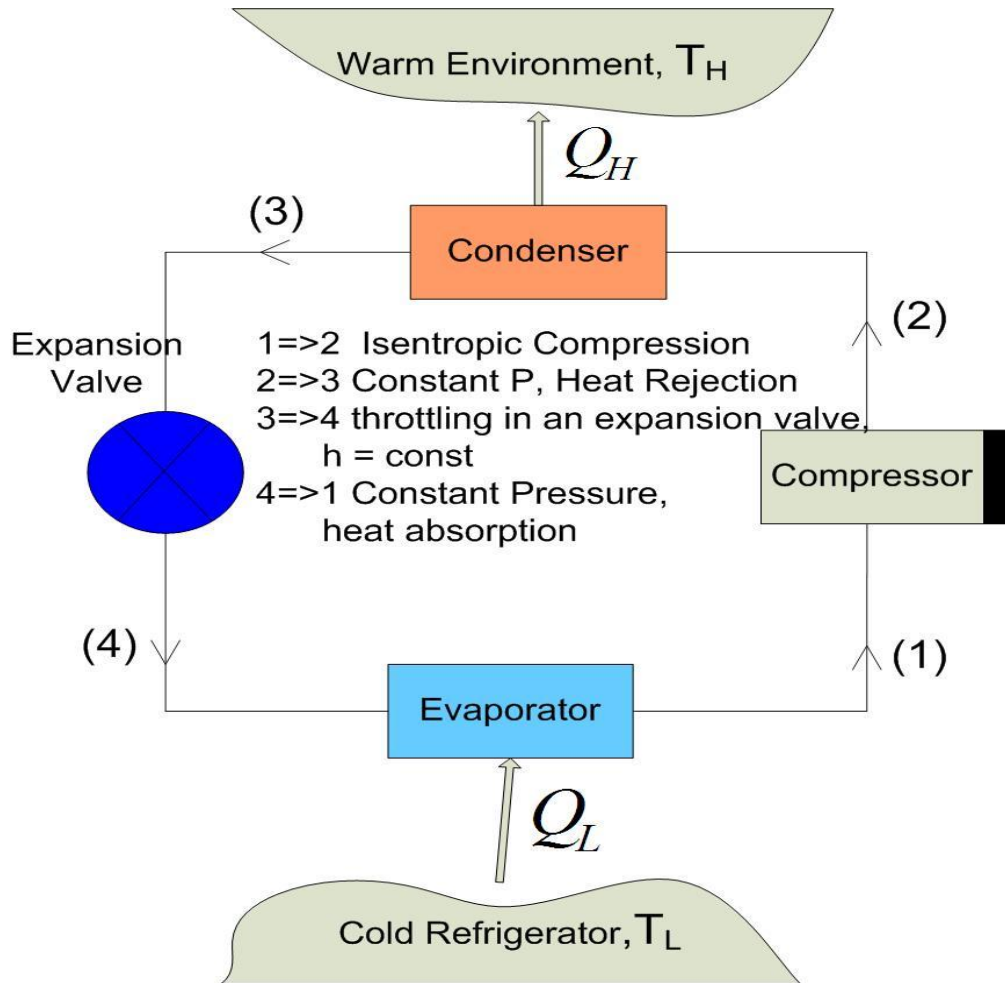

## **Choice of compressor, design of condenser, evaporator determined by**

- Refrigerant
- Required cooling
- Load
- Ease of maintenance
- Physical space requirements
- Availability of utilities (water, power)

The most common refrigeration system in use today involves the input of work (from a compressor) and uses the Vapor Compression Cycle. The purpose of these notes is to introduce some important features of this type of refrigeration system and to discuss how such systems can be thermodynamically modeled. In a vapor compression refrigeration system a gas is alternatively compressed and expanded and goes from the liquid to the vapor state. The basic components of a vapor-compression refrigeration system are shown below.

Unit – IV,

*Refrigeration and Air-Conditioning*

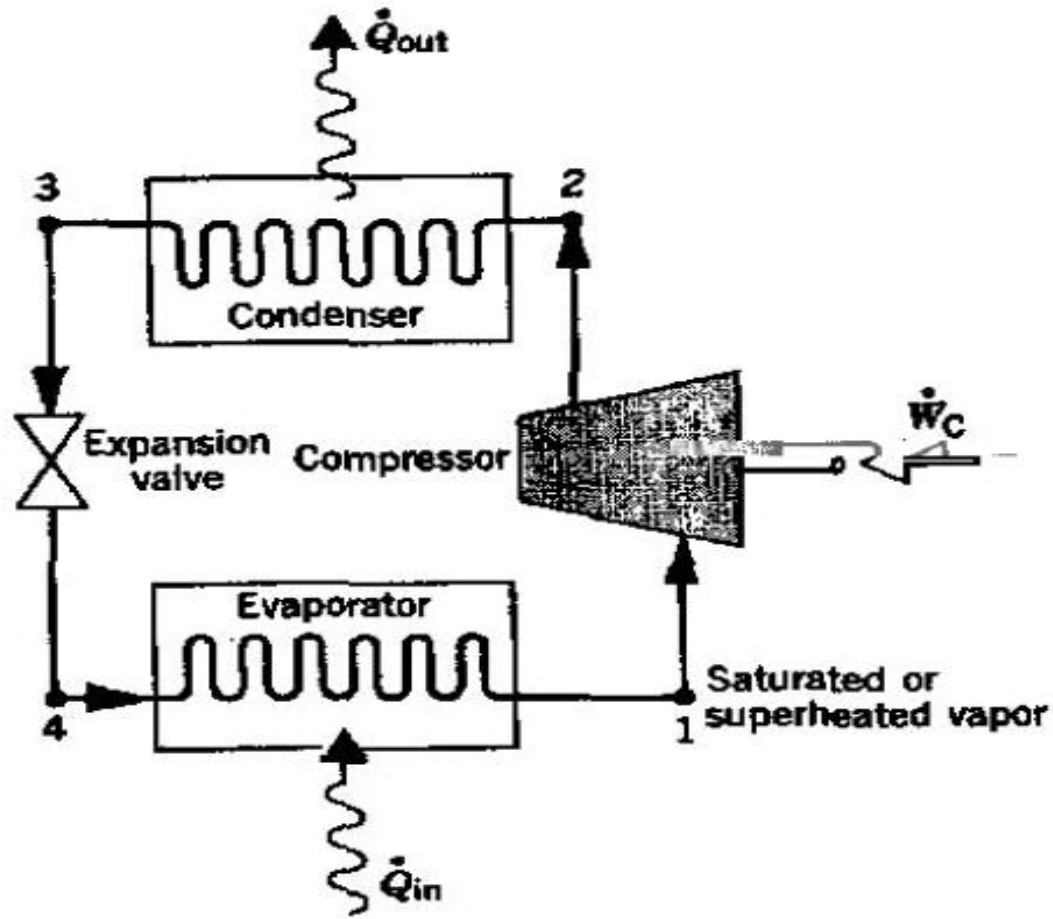

Unit - III

Typical vapor compression refrigeration cycle diagram.

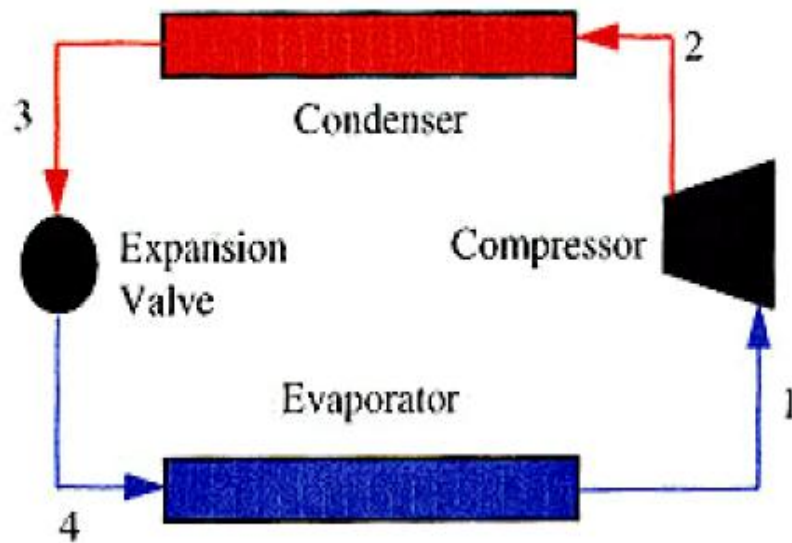

T-s Diagram

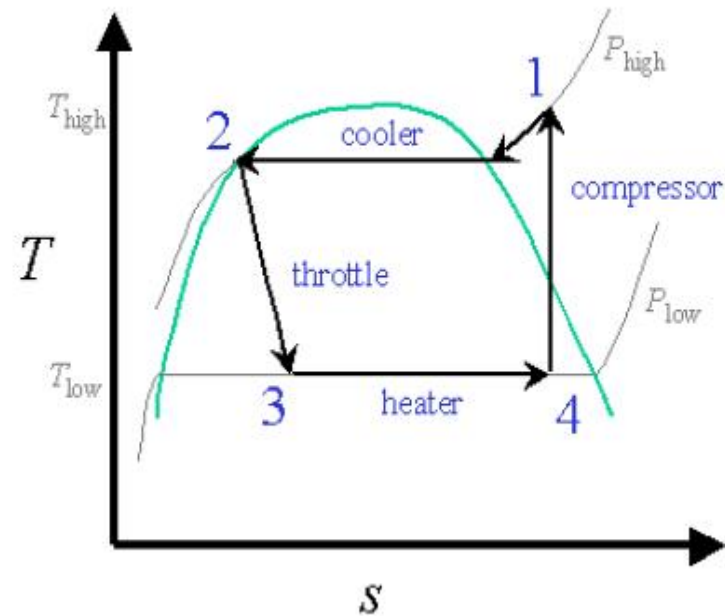

The four basic components of the vapour compression refrigeration system are thus:

1. evaporator - Heat is absorbed to boil the liquid at a low temperature, therefore a low pressure must be maintained in this section.
2. compressor - The compressor does work on the system increasing the pressure from that existing in the evaporator (drawing in low- pressure, low-temperature saturated vapour) and to that existing in the condenser (i.e., delivering high pressure and high temperature vapour to the condenser).

3. condenser - The high pressure, high temperature (superheated or saturated) vapour that enters the condenser has heat removed from it and as a result it is condensed back into a liquid phase.

4. throttle valve - The high pressure liquid from the condenser is expanded through this valve, allowing its pressure to drop to that existing in the evaporator.

As already mentioned, Vapor-compression refrigeration systems are the most common type of refrigerator in use today.

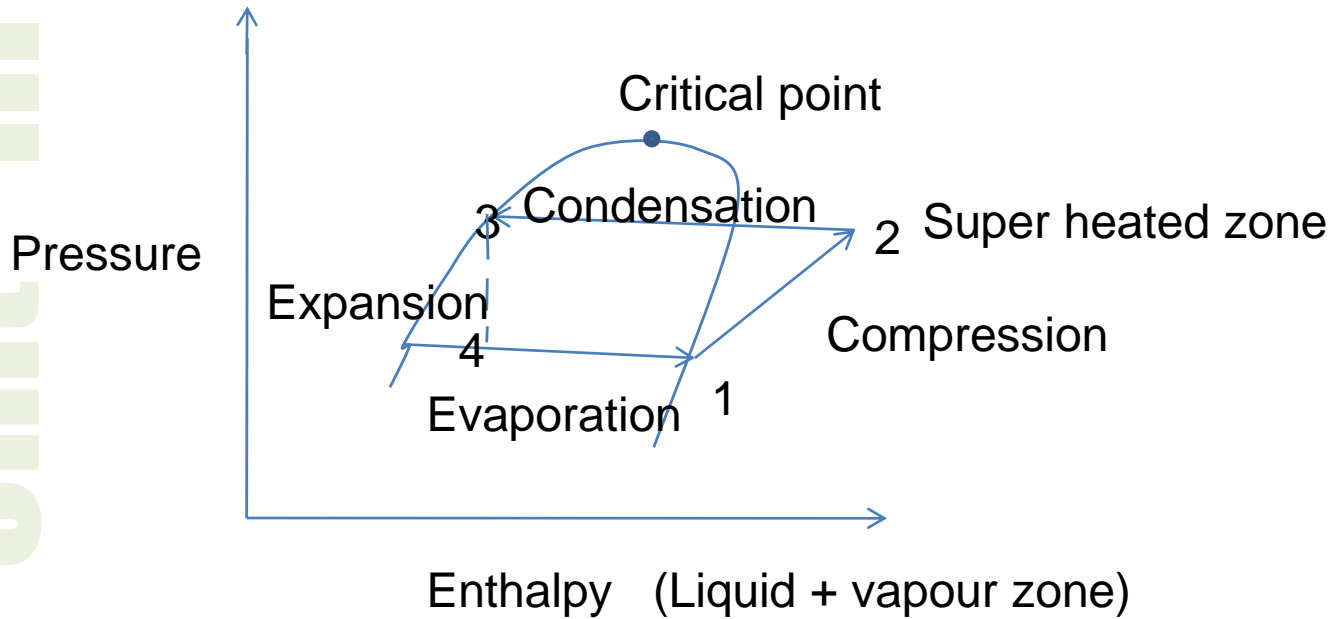

- 1-2 – Compression
- 2-3 – Condensation
- 3-4 - Expansion
- 4-1 – Evaporation.

The Refrigerant absorbs heat from cooling cabinet and refrigerant changes from liquid phase to vapour phase. Rejects the heat in condenser and again the refrigerant changes from vapour to liquid phase. The condensing medium is air.

1-2 compression – low temp vapour refrigerant at evaporator pressure  $P_e$  – enters compressor at point 1 – compressed till pt 2 – temp and pressure increases  $P_c$  – work input electrical energy - enthalpy increases.

2-3 Condensation – high temp refrigerant enter condenser – temp higher than surroundings (air) - heat transfers to surroundings – vapour cools and changes to liquid – till pt 3.

### 3-4 Expansion

Expansion at throttle valve – both temp & pressure drops – till pt 4. partial evaporation of the liquid refrigerant take place resulting two phase mixture at evaporator inlet.

### 4-1 Evaporation

Above mixture enters evaporator – cold refrigerant absorbs heat from cooling compartment – refrigerant changes from liquid to vapour form – this process which results in cooling of high temp system is known as refrigerating effect. Then low temp refrigerant enters compressor at pt 1.

The cycle repeats.

## Vapour absorption system

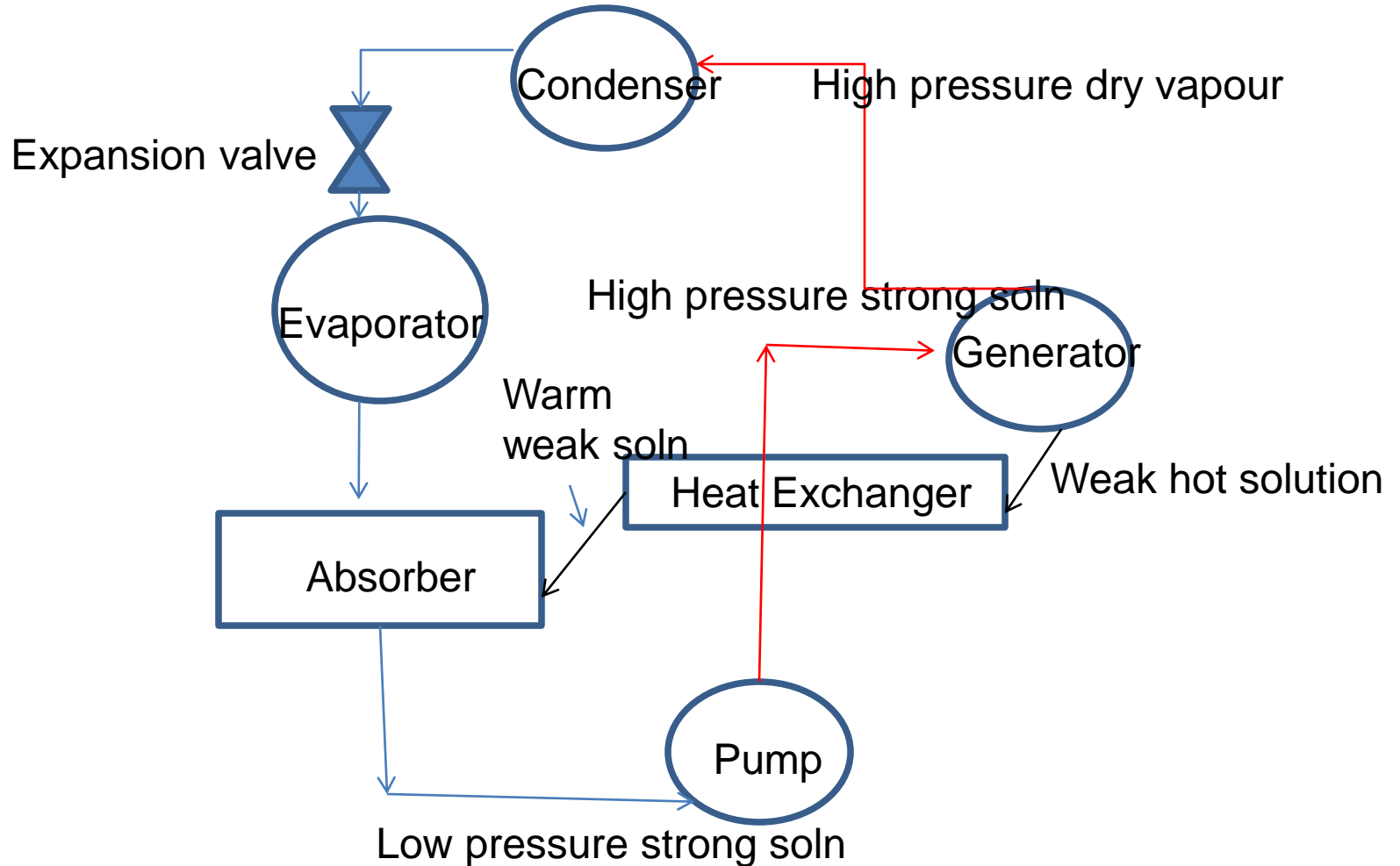

## Vapour absorption refrigeration:

Heat is employed instead of work – produce refrigerating effect – the compressor replaced by vapour generator, absorber, liquid pump.

Absorber is to absorb the refrigerant vapour by its weak solution and to form strong soln using absorbent – it should be chemically stable with high boiling point & low specific heat. Ex- in ammonia – water absorbant.

Pump: rise pressure of rich soln – absorber to condenser and to generator.

Generator : separate vapour from rich soln – send weak soln to absorber.

Low pressure strong ammonia enters pump – pressure increased – supplied to generator. Generator receives heat from coil – strong soln heated – dry ammonia given from surface – weak ammonia soln – high temp refrigerant vapour enters condenser – it rejects heat to atmosphere – so condensation takes place – liquid ammonia soln expands in expansion valve – partial evaporation.

The soln enters evaporator – absorbs heat from cooling compartment and convert into dry vapour then enters to absorber. Water in absorber absorbs ammonia and converts into strong soln – the warm weak ammonia soln from heat exchanger mixes with strong soln in absorber – this strong soln again recalculated using pump and the cycle repeats.

# Vapour Absorption Refrigeration

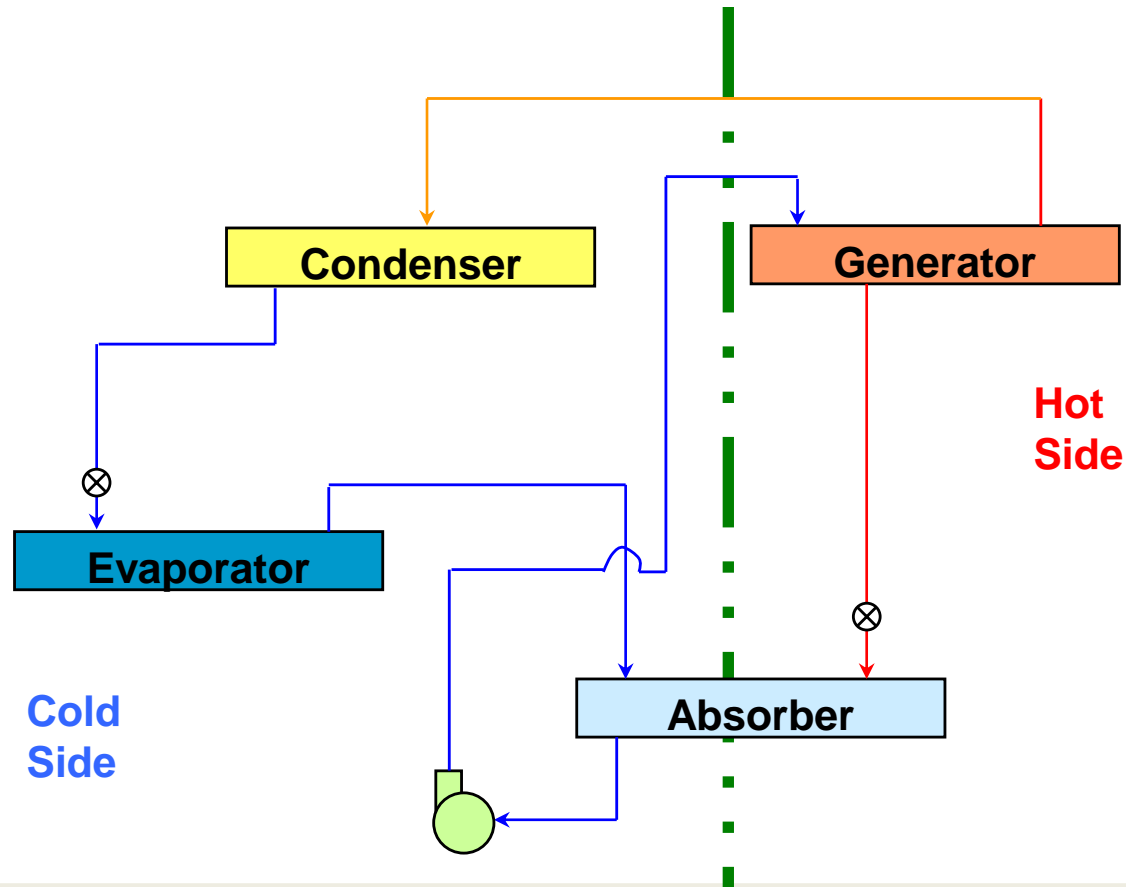

**Comparison**

Vapour compression

- Mech energy
- Ref. capacity less than 1000 tons
- COP higher 4 to 10
- Noisy
- Simple refilling of refrigerant
- Chance of leakage
- High operation & maintenance cost
- Small in size
- More wear and tear

Vapour absorption

- heat energy
- greater
- cop is less
- noise less
- difficulty
- less
- less
- larger
- less

## AIR CONDITIONING

Is a process of treating air with respect to temp, humidity, and cleanness and distribute it as per requirements of the conditioned space.

Classified into two types:

- a) Comfort air conditioning –
  - a) Summer – reduce heat & water content of air by cooling & dehumidifying.
  - b) Winter – increase heat & water content of air by heating.
  - c) year round : control temp & moisture content as per season
- b) Industrial : Purpose – provide reqd temp & moisture content.

Principle of air conditioning:

It operates on the principle of refrigeration by cooling the air drawn from the conditioned space and returning the cool air to the conditioned space.

Room Air Conditioner

Components:

- a) Compressor
- b) Condenser
- c) Evaporator
- d) Capillary tube
- e) Condenser & evaporator fans- driven by motors

Evaporator fan & coil – inside the building / space – to be air conditioned

Condenser & Condenser fan – outside building to transfer the heat with the atmosphere.

Low pressure vapour refrigerant from evaporator – compressor - High pressure and temp vapour refrigerant – fm compressor – condenser – heat is dissipated to atm - air drawn and circulated from outside to condense vapour – liquid high pressure passed thro capillary tube - temp & pressure falls – starts boiling by absorbing heat from evaporator and vaporises – again drawn to compressor t next cycle.

The air from the room to be cooled is drawn – then passed thro evaporator – it losses heat by giving heat to refrigerant in evaporator. Cooled and dehumidified air passed thro dampers to circulate in room.

An electric heater is inbuilt to get hot air in winter.

### Applications of Air Conditioners

- 1) Industrial: to control chemical & bio chemical reactions – Photographic, textile, printing, m/c tool
- 2) Commercial: Theaters, hotels, banks, Dept. stores
- 3) Transport: Automobiles, Trains, aircraft, ships
- 4) Special: Computer centers, hospitals.

### Central Air Conditioning:

Used in public buildings, stores, theaters is central air conditioning.

All the components of system are grouped together in one central room and conditioned air is distributed from central room to the required space through ducts. The capacity of system is usually 25 tons.

System contains heating oils, cooling & dehumidifying coils, sprays for cooling & dehumidifying, blower with motor, air cleaning equipments, control devices etc are assembled at site.